



WF-200™

Computer Weld Technology's WF-200™ Capstan Wire Feed System is designed specifically for use in automated welding applications. It's compact size and light weight (5 lbs without a welding torch) permits the Capstan to be mounted directly on an automated fixture or a robot wrist. This eliminates the requirement for wire guide conduits / liners normally associated with most conventional wire feed units. The Capstan also provides increased wire drive contact area by wrapping the welding wire around the drive wheel (for approximately 20% of the drive wheel surface) providing several major benefits that are listed below. The patented Capstan Wire Feed System provides the end user the ultimate solution in affordable wire feed technology and reliability. From a control standpoint the Capstan can be interfaced to a welding fixture or robot controller using Computer Weld Technology's Wire Feed Drive Control System.

WF-200™

CAPSTAN WIRE FEED



The WF-200™ drive produces a positive, slip free drive force to the filler material, without damaging or flattening the wire surface. This provides exceptional feeding capability of "soft" wires such as aluminum and copper. The Capstan drive wheel plastically deforms the wire which removes residual cast and permits precise wire placement in the weld puddle.

FEATURES

- Compact / Lightweight design
- Universally adaptable for broad application range
- Plastically deforms wire
- Positive wire feed force
- Eliminates surface damage
- "Cold Wire" and "Hot Wire" Articulators are available
- Standard and opposite hand models are available

BENEFITS

- Can be mounted on robot wrist or automated welding fixture
- Interface with most manufacturer's welding equipment, robots and fixtures
- Eliminates residual wire cast providing repeatable, precise wire placement
- Eliminates wire slip
- Exceptional feeding of "soft wire" such as aluminum and copper
- Can be used with all welding processes (MIG, TIG, Plasma Arc, E.B. and Laser)
- Offers flexibility in design of welding fixtures

WF-200™ SPECIFICATIONS

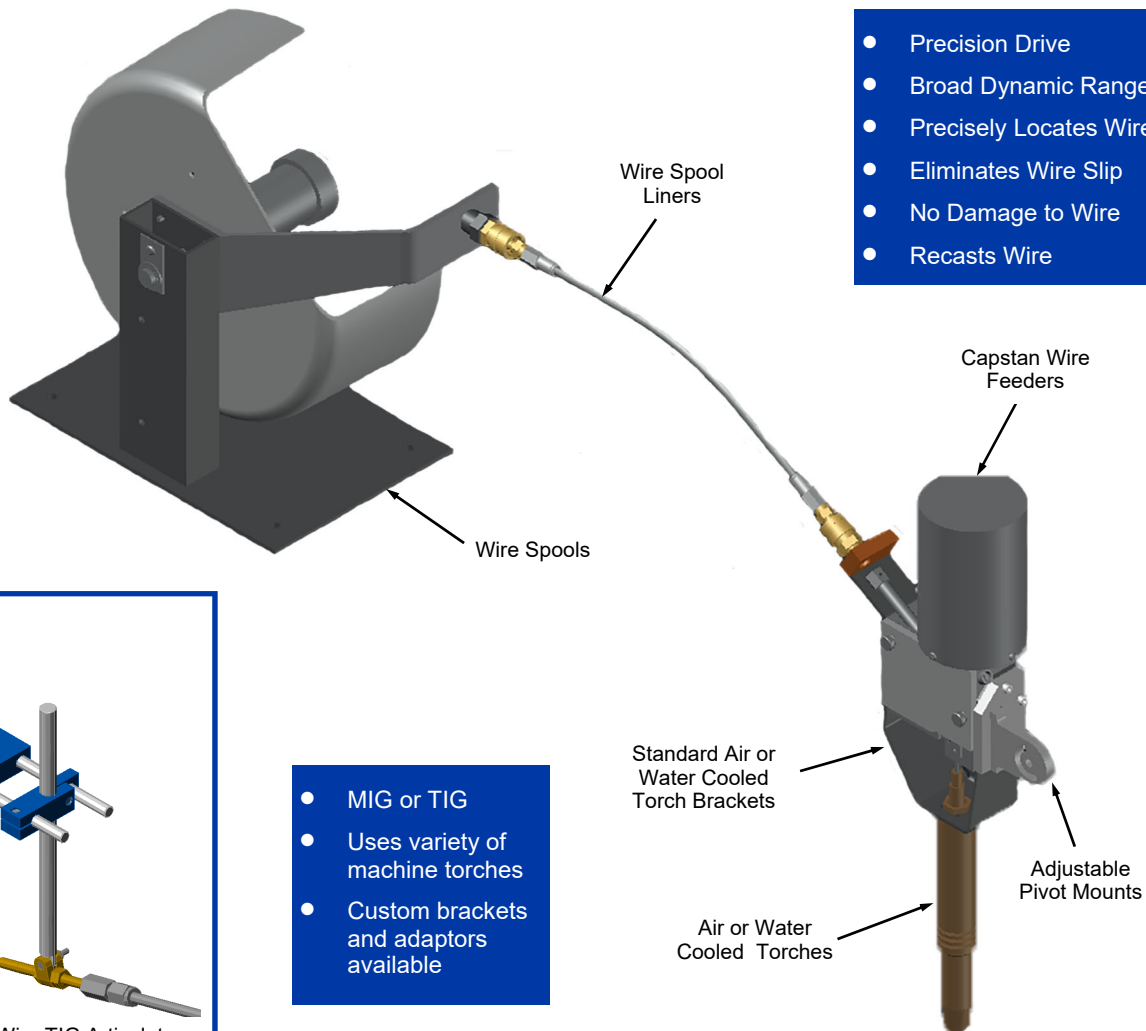

- Precision Drive
- Broad Dynamic Range
- Precisely Locates Wire
- Eliminates Wire Slip
- No Damage to Wire
- Recasts Wire

- MIG or TIG
- Uses variety of machine torches
- Custom brackets and adaptors available

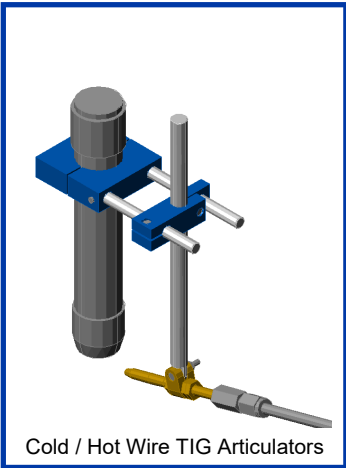

MECHANICAL SPECIFICATIONS

Wire Size:	Soft Wire: 0.030 to 0.062 (.8mm - 1.6mm) Hard Wire: 0.030 to 0.052 (.8mm - 1.3mm)
Height:	9-1/8" (232mm) Standard Speed Model 10-3/8" (264mm) Low Speed Model
Width:	4-5/8" (118mm)
Length:	4-3/8" (112mm)
Weight:	5 lbs (2.27 kg) <i>without torch for Standard Speed</i> 5.1 lbs (2.31 kg) <i>without torch for Low Speed</i>
Wire Feed Speed Range:	10 - 575 IPM (4-265mm/s) Standard Speed Model 4 - 100 IPM (1.7-42mm/s) Slow Speed Model
Motor Full Load Pull Capacity:	20 lbs (9kg) - 9cm Motor Model
Motor Full Load Current:	3.0 Amps
Motor Full Load Voltage:	12 VDC

Note: Specifications subject to change without notice.